

Submersible drainage sump pump made of stainless steel AISI 304, shaft sealing is with double lip seals that run on a ceramic-coated shaft. Suitable for draining wells, plant room sumps, and lift shafts, emptying, pools, sumps, small-scale irrigation and small water displays and pub cellars. Options include with - without float switch - VOX versions and 110 - 230 - 400V versions. (10 m cable H05 RN-F on request)



### SPECIFICATIONS

- Maximum liquid temperature: 35°C according EN 60335-2-41 for domestic uses 40°C for other uses
- Maximum immersion: 5 m
- Maximum passage of solids: 10 mm 20 mm per VOX version

### MATERIALS

- Pump casing, impeller strainer, cover, casing cover and motor casing in AISI 304
- Shaft in AISI 303
- Double lip seal with interposed oil chamber

### TECHNICAL DATA

- Asynchronous 2 poles motor
- Insulation class F
- Protection degree IP68
- 1~230V ± 10%, 50Hz
- DNM 1" 1/4

### DIMENSIONAL TABLE

Pump type	(mm)		
	H	H1	S
BEST ONE	260	220	10
BEST ONE VOX	285	245	20

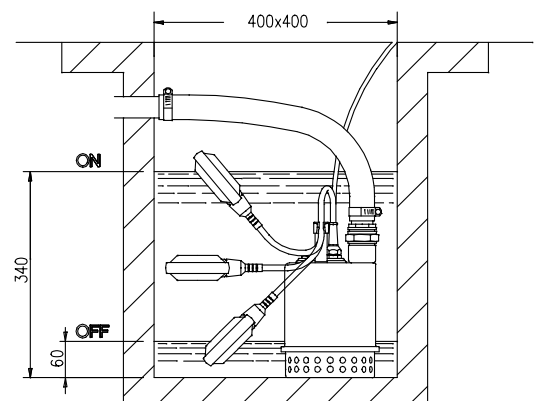
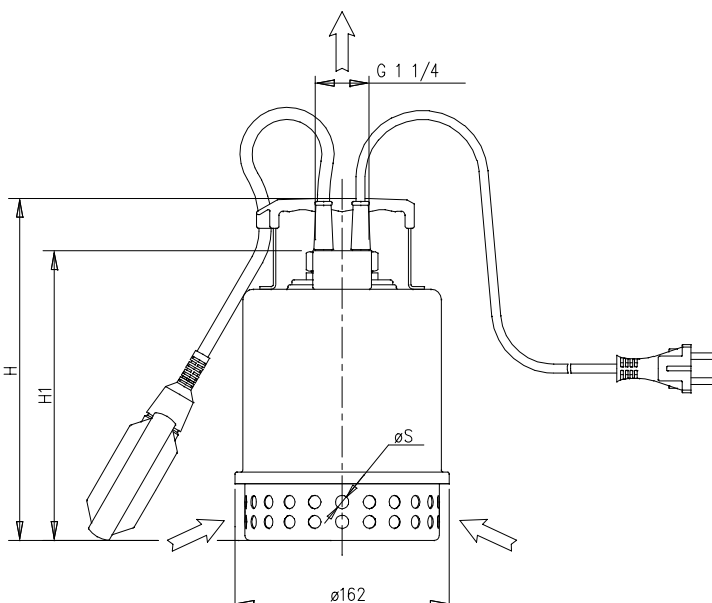

### PERFORMANCE CURVES (according to ISO 9906 Annex A)

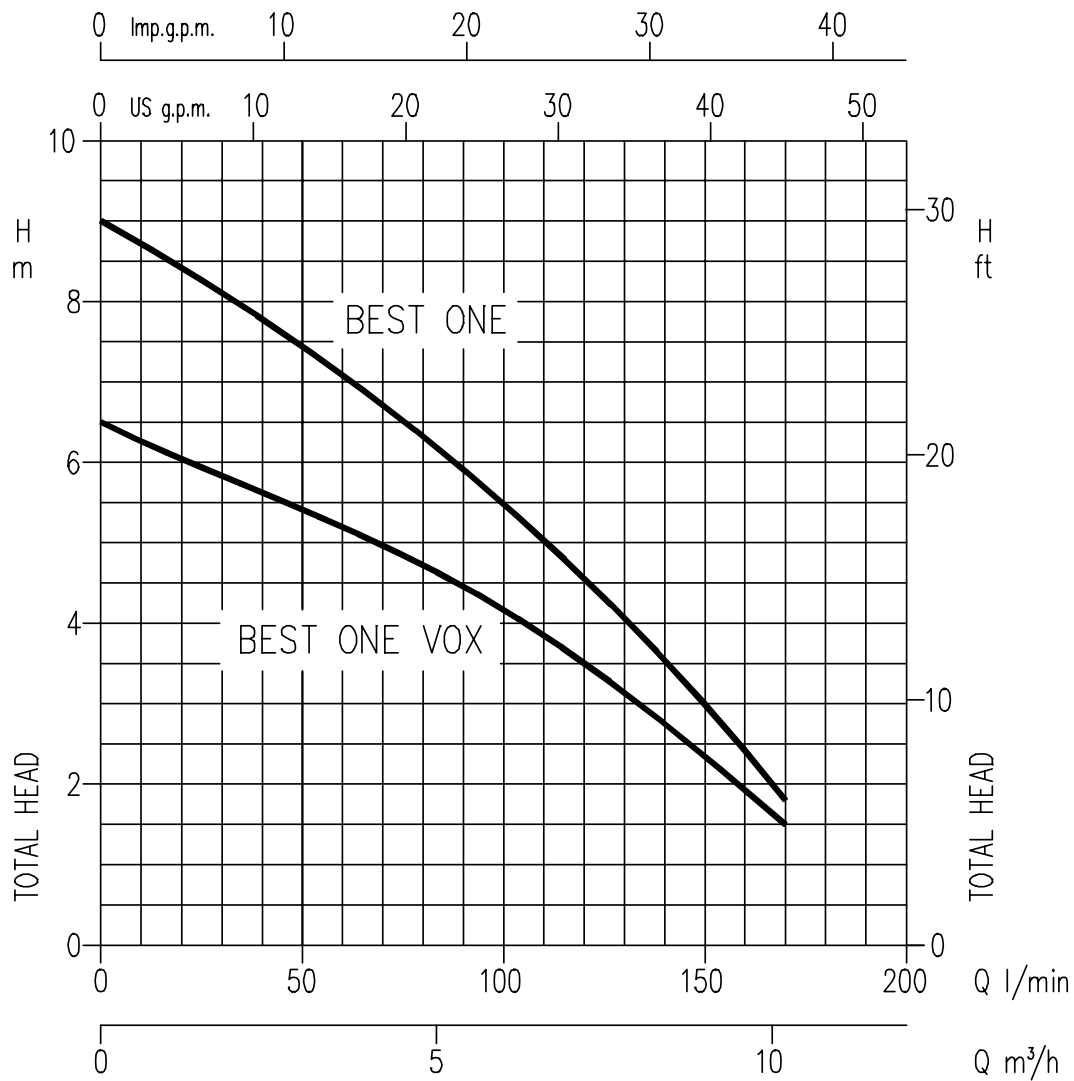

### PERFORMANCE TABLE

Pump type Single-phase 230V 50Hz	kW	Capacitor		Abs. Current (A) Single-phase	Q=Capacity l/min m³/h	H=Total head					
		μF	V <sub>c</sub>			20	40	80	120	160	170
BEST ONE	0,25	8	450	2,2		8,3	7,8	6,3	4,5	2,4	1,8
BEST ONE VOX	0,25	8	450	2,0		6	5,6	4,8	3,5	2	1,5